

NATURAL SCIENCES
ADMISSIONS ASSESSMENT

D568/12

November 2021

60 minutes

SECTION 2

INSTRUCTIONS TO CANDIDATES

Please read these instructions carefully, but do not open this question paper until you are told that you may do so. This paper is Section 2 of 2.

A separate answer sheet is provided for this paper. Please check you have one. You also require a soft pencil and an eraser.

Please complete the answer sheet with your candidate number, centre number, date of birth, and name.

This paper contains **three** parts: **X**, **Y** and **Z**.

All candidates should complete only **one** part chosen from:

Part X	Physics
Part Y	Chemistry
Part Z	Biology

Each part has 20 multiple-choice questions. There are no penalties for incorrect responses, only marks for correct answers, so you should attempt **all** 20 questions in your chosen part. Each question is worth one mark.

For each question, choose the **one** option you consider correct and record your choice on the separate answer sheet. If you make a mistake, erase thoroughly and try again.

You **must** complete the answer sheet within the time limit.

You can use the question paper for rough working, but **no extra paper** is allowed. Only your responses on the answer sheet will be marked.

A Periodic Table is included.

Dictionaries and calculators are NOT permitted.

Please wait to be told you may begin before turning this page.

This question paper consists of 67 printed pages and 5 blank pages.



BLANK PAGE

Paper content

Periodic Table	5
PART X Physics.....	7
PART Y Chemistry	29
PART Z Biology.....	51

BLANK PAGE

H 1																	He 2		
Li 3	Be 4															F 9	Ne 10		
Na 11	Mg 12													Al 13	Si 14	P 15	S 16	Cl 17	Ar 18
K 19	Ca 20	Sc 21	Ti 22	V 23	Cr 24	Mn 25	Fe 26	Co 27	Ni 28	Cu 29	Zn 30	Ga 31	Ge 32	As 33	Se 34	Br 35	Kr 36		
Rb 37	Sr 38	Y 39	Zr 40	Nb 41	Mo 42	Tc 43	Ru 44	Rh 45	Pd 46	Ag 47	Cd 48	In 49	Sn 50	Sb 51	Te 52	I 53	Xe 54		
Cs 55	Ba 56	<i>Lanthanoids</i> 57-71		Ta 73	W 74	Re 75	Os 76	Ir 77	Pt 78	Au 79	Hg 80	Tl 81	Pb 82	Bi 83	Po 84	At 85	Rn 86		
Fr 87	Ra 88	<i>Actinoids</i> 89-103		Db 105	Sg 106	Bh 107	Hs 108	Mt 109	Ds 110	Rg 111	Cn 112	Nh 113	Fl 114	Mc 115	Lv 116	Ts 117	Og 118		

symbol
atomic number

Lanthanoids	La 57	Ce 58	Pr 59	Nd 60	Pm 61	Sm 62	Eu 63	Gd 64	Tb 65	Dy 66	Ho 67	Er 68	Tm 69	Yb 70	Lu 71
Actinoids	Ac 89	Th 90	Pa 91	U 92	Np 93	Pu 94	Am 95	Cm 96	Bk 97	Cf 98	Es 99	Fm 100	Md 101	No 102	Lr 103

BLANK PAGE

PART X Physics

- 1 Two loudspeakers are positioned 8.0 m apart as shown.

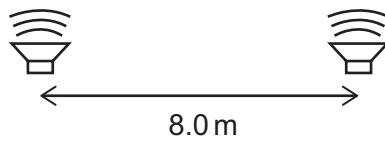

The loudspeakers emit sound waves of the same single frequency. The wave emitted by one loudspeaker is 180° out of phase with the wave emitted by the other loudspeaker.

A point P is in front of the loudspeakers. P is 18.0 m from one loudspeaker and 24.0 m from the other loudspeaker. As a result of superposition of the two waves arriving at P, the amplitude of the sound at position P is a minimum.

The speed of the sound is 336 m s^{-1} .

What is the lowest possible frequency of the sound?

- A 21 Hz
- B 28 Hz
- C 42 Hz
- D 56 Hz
- E 63 Hz
- F 84 Hz

2 A block is at rest on a rough inclined plane.

The acute angle between the plane and the horizontal is greater than 45° .

The forces acting on the block are: friction (F), weight (W) and normal contact force (N).

How do the magnitudes of the three forces compare?

A $F < N < W$

B $F < W < N$

C $N < F < W$

D $N < W < F$

E $W < F < N$

F $W < N < F$

- 3 A dc power supply, a resistor of constant resistance $50\ \Omega$ and a piece of resistance wire are connected in series.

The length of the resistance wire is 20 m and its cross-sectional area is $0.10\ \text{mm}^2$. The wire is made from a material with resistivity $1.0 \times 10^{-7}\ \Omega\ \text{m}$ and the current in it is 200 mA.

What is the voltage across the terminals of the power supply?

- A 4.0V
- B 6.0V
- C 9.9V
- D 10.0V
- E 10.1V
- F 12.0V
- G 14.0V

- 4 Two objects of mass M and m are connected by a rope over a pulley on an inclined plane as shown.

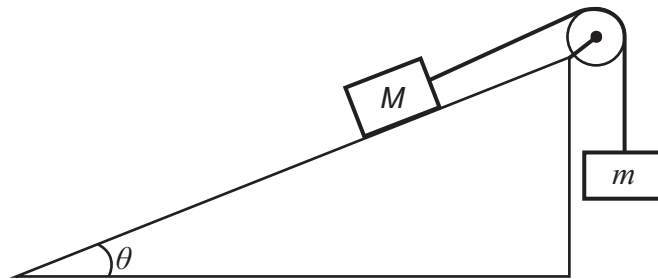

[diagram not to scale]

There is no friction between the plane and the object. The pulley is smooth, and the rope has negligible mass.

The angle θ of the plane to the horizontal is such that $\sin \theta = 0.80$ and $\cos \theta = 0.60$.

The object with mass M accelerates down the slope.

Which expression describes the full range of possible values of M compared with m ?

- A $M > \frac{3}{5}m$
- B $M > \frac{4}{5}m$
- C $M > m$
- D $M > \frac{5}{4}m$
- E $M > \frac{5}{3}m$

- 5 An object P falls vertically from rest through air and reaches terminal velocity.

An identical object Q is projected vertically upwards from the ground.

When Q reaches its maximum height, P collides with it. The two objects join together in such a way that there is no change to the area of cross section passing through the air.

The two combined objects then fall through the air as one object.

Which sketch graph shows the variation of velocity with time for object P before and after the collision?

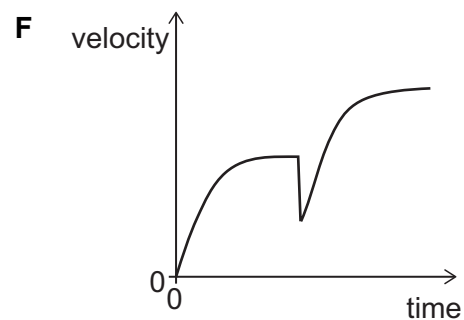
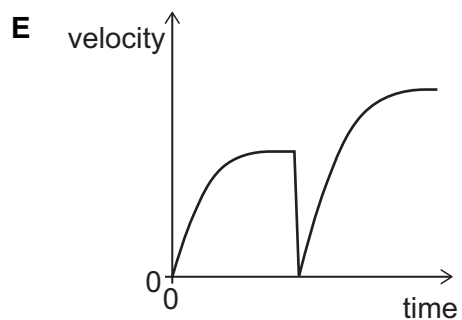
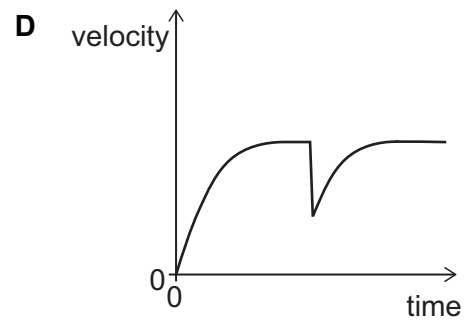
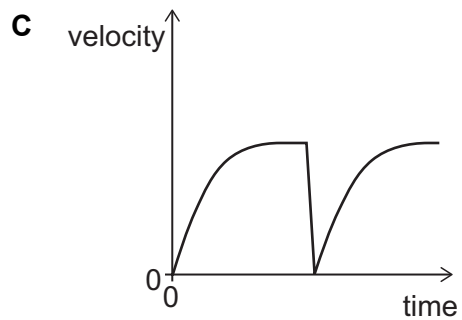
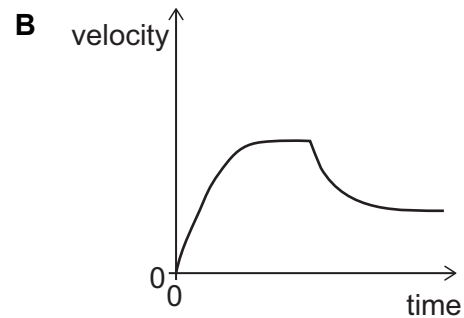
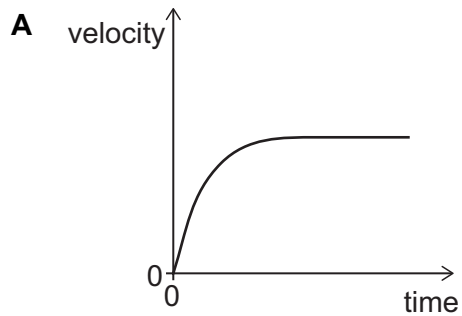

- 6 A lorry of mass m has an engine that develops a constant mechanical output power P .

The lorry is accelerated from rest by the engine in a horizontal straight line. The lorry experiences a total resistive force that is always proportional to the square of its speed.

The process is repeated for different values of P , and the maximum speed of the lorry is found to be proportional to P^n , where n is a constant.

What is the value of n ?

- A $\frac{1}{3}$
- B $\frac{1}{2}$
- C 1
- D 2
- E 3

- 7 A battery pack consists of 6 cells, each with an emf of 1.50 V and each with an internal resistance of $0.20\ \Omega$.

The cells are arranged in two rows connected in parallel. Each row contains 3 cells connected in series.

The battery pack is connected to an external resistor of resistance $1.20\ \Omega$.

What is the electrical power transferred in the external resistor?

- A 2.7 W
- B 3.6 W
- C 7.5 W
- D 10.8 W
- E 13.5 W
- F 43.2 W

- 8 A light spring is used to support a uniform rod horizontally against a wall as shown. The angle between the spring and the rod is θ .

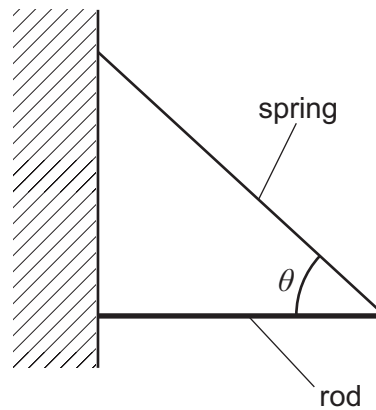

The spring constant of the spring is 20 N m^{-1} and the weight of the rod is 16 N .

The angle θ is such that $\cos \theta = \frac{3}{5}$ and $\sin \theta = \frac{4}{5}$.

How much energy is stored in the spring?

- A 1.6 J
- B 2.5 J
- C 3.2 J
- D 4.4 J
- E 5.0 J
- F 6.4 J
- G 10 J
- H 40 J

- 9 An object of mass 2.0 kg moves in a straight line under the action of a resultant force.

The displacement x of the object from its position at time $t = 0$ is given by

$$x = 4.0t^3$$

where x is in metres and t is in seconds.

At $t = 5.0$ s, what is the rate of change of momentum of the object?

- A 6.7 kg m s^{-2}
- B 66.7 kg m s^{-2}
- C 120 kg m s^{-2}
- D 240 kg m s^{-2}
- E 600 kg m s^{-2}

- 10** In an industrial process to test the purity of a metal, a narrow beam of ultrasound passes into a block of the metal. The ultrasound generator U is immersed in a gel that is in contact with the metal. The ultrasound passes from the gel into the metal.

The arcs of circles shown in the gel are lines that represent the positions of the compressions (known as wavefronts) of the ultrasound wave that comes from U.

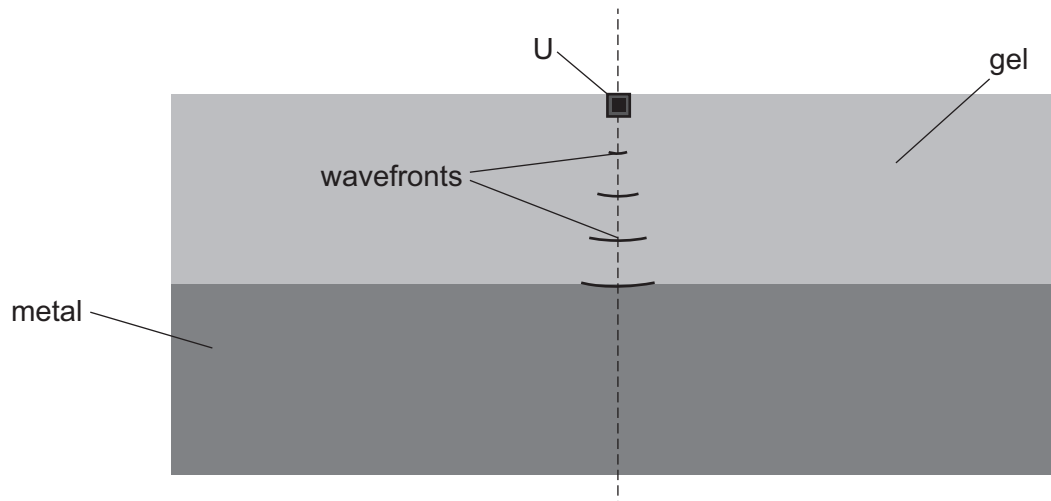

Ultrasound travels faster in the metal than in the gel.

The wavefronts in the metal are circular arcs with their centre at a point X that is on the dashed line.

Where on the dashed line is X?

- A** above U
- B** at U
- C** in the gel below U
- D** on the boundary between the gel and the metal
- E** in the metal

- 11 The diagram shows a circuit containing two power supplies with negligible internal resistance and two resistors with resistances R and $5R$.

The emfs of the power supplies and the magnitude and direction of the current in one part of the circuit are shown.

One point in the circuit is labelled P.

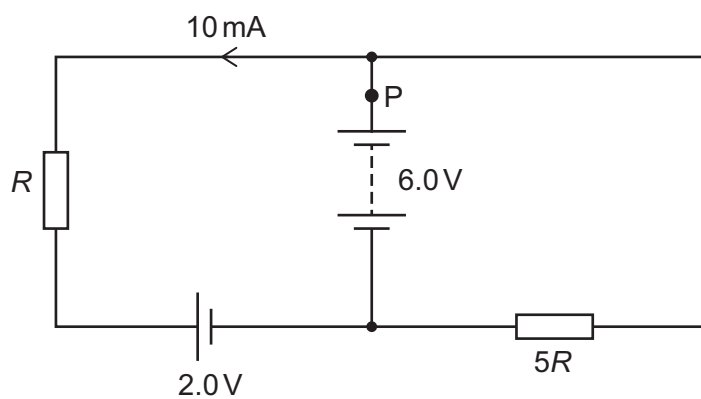

What is the magnitude of the current at P?

- A 3.0 mA
- B 7.0 mA
- C 8.5 mA
- D 11.5 mA
- E 13 mA
- F 25 mA

- 12 A selection of five wires made from the same metal have different unstretched lengths but equal masses. The wires are all subjected to the same small tension force and each wire extends within its limit of proportionality.

Which graph shows the relationship between the extension of the wires and the unstretched length of the wires?

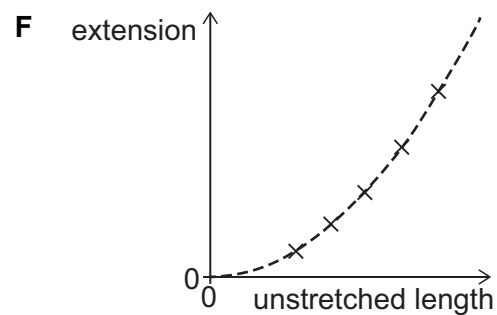
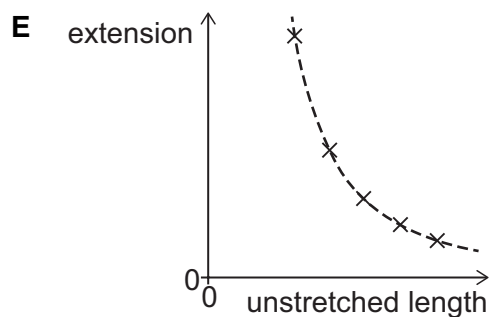
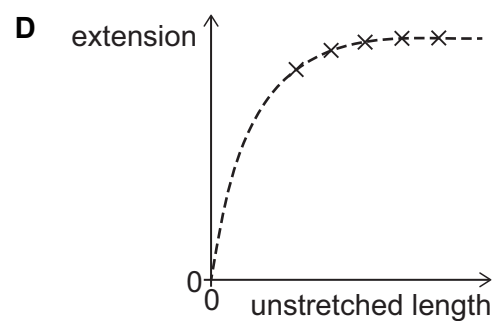
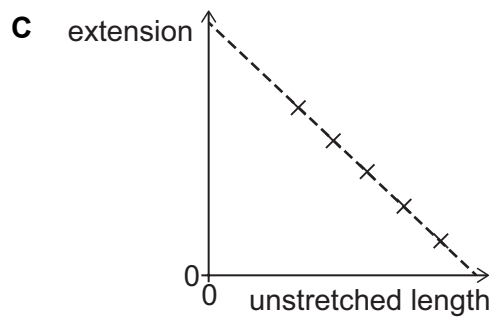
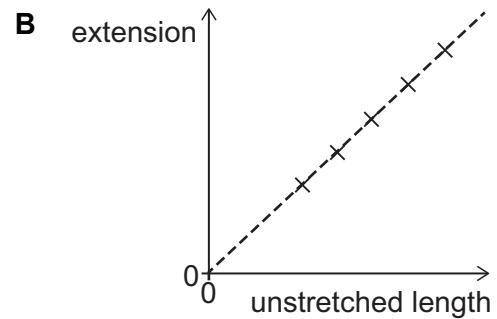
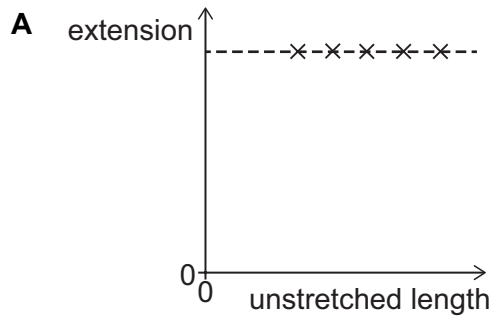

- 13 Water enters a horizontal pipe of cross-sectional area 0.0040 m^2 at constant speed 0.50 m s^{-1} . At the end of the pipe the cross-sectional area reduces to 0.0020 m^2 and the water leaves the pipe as shown. The density of water is 1000 kg m^{-3} .

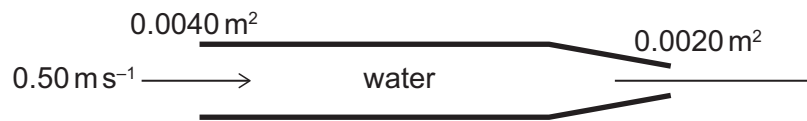

How much power must be supplied to the water to maintain the flow in this section of the pipe?

(Assume that the water is incompressible and that frictional forces can be neglected.)

- A 0.25 W
- B 0.50 W
- C 0.75 W
- D 1.0 W
- E 1.25 W
- F 1.5 W
- G 3.75 W

- 14 Two light wires P and Q support a load of weight W in equilibrium as shown. Wire P is horizontal and wire Q is at an angle of 60° to the vertical. The wires are made from the same material.

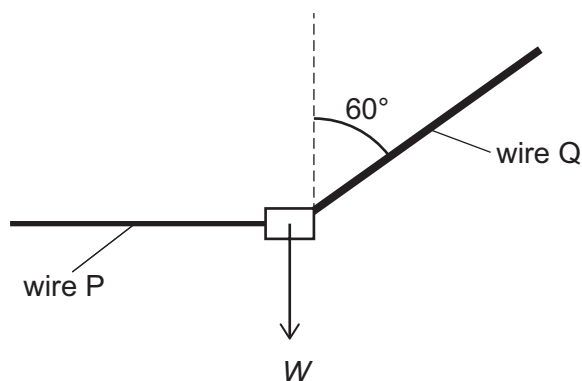

The radius of wire Q is twice the radius of wire P.

What is the ratio

$$\frac{\text{strain in wire P}}{\text{strain in wire Q}} ?$$

(The wires do not exceed their limits of proportionality.)

- A $\frac{\sqrt{3}}{8}$
- B $\frac{\sqrt{3}}{4}$
- C $\frac{\sqrt{3}}{2}$
- D $\sqrt{3}$
- E $2\sqrt{3}$
- F $\frac{4}{\sqrt{3}}$
- G $\frac{8}{\sqrt{3}}$

- 15 The speed of light in a block of glass is $2.0 \times 10^8 \text{ m s}^{-1}$. The block of glass is immersed in a liquid of refractive index 1.2.

The diagram shows a ray of light travelling in the glass block striking the side of the block at the point labelled X. The acute angle between the ray and the side of the block is θ .

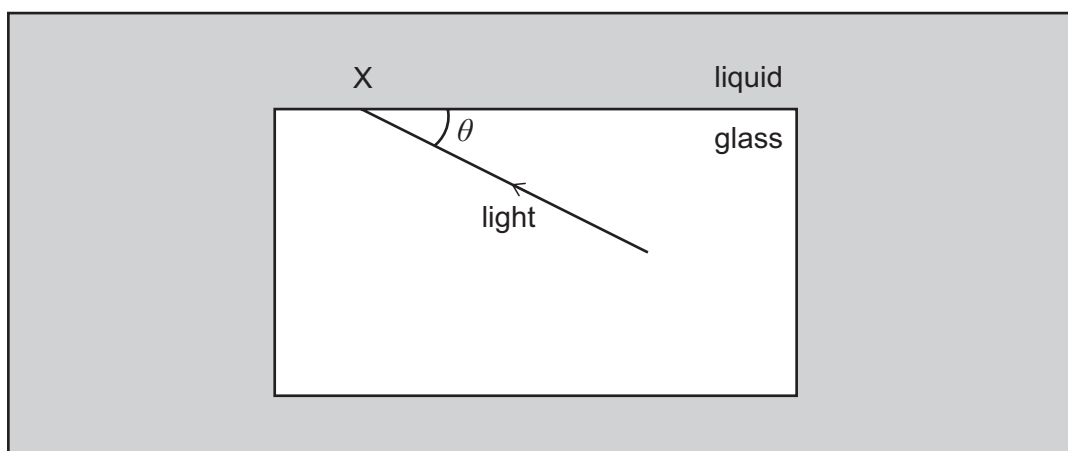

What is the full range of values of the acute angle θ for which light is refracted at X?

(The speed of light in a vacuum is $3.0 \times 10^8 \text{ m s}^{-1}$.)

- A $0^\circ < \theta < \cos^{-1}\left(\frac{2}{3}\right)$
- B $0^\circ < \theta < \cos^{-1}\left(\frac{\sqrt{5}}{3}\right)$
- C $0^\circ < \theta < \cos^{-1}\left(\frac{3}{5}\right)$
- D $0^\circ < \theta < \cos^{-1}\left(\frac{4}{5}\right)$
- E $\cos^{-1}\left(\frac{2}{3}\right) < \theta < 90^\circ$
- F $\cos^{-1}\left(\frac{\sqrt{5}}{3}\right) < \theta < 90^\circ$
- G $\cos^{-1}\left(\frac{3}{5}\right) < \theta < 90^\circ$
- H $\cos^{-1}\left(\frac{4}{5}\right) < \theta < 90^\circ$

- 16 A car is at rest on a straight horizontal road. At time $t = 0$ s the car starts to move along the road. The graph shows how its acceleration varies from $t = 0$ s to $t = 20$ s.

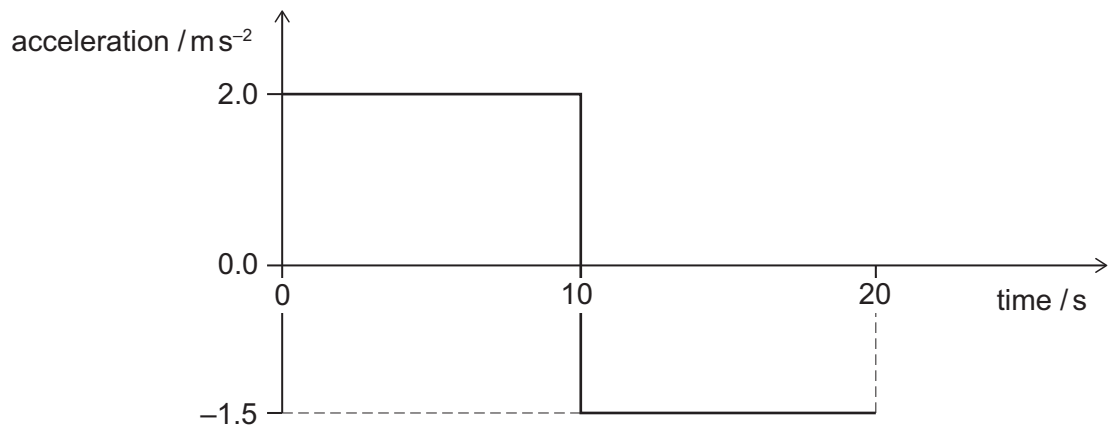

What is the displacement of the car from its starting position when $t = 20$ s?

- A 5.0 m
- B 25 m
- C 35 m
- D 175 m
- E 225 m
- F 375 m

- 17 An empty measuring cylinder is placed on a balance, and the balance reading is then set to zero.

A mass of 8.7 g of a powder is poured into the measuring cylinder as shown in the diagram.

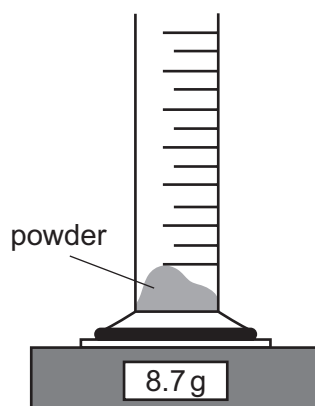

Liquid is poured into the cylinder to cover the powder completely. The powder does not dissolve. The reading on the measuring cylinder and the reading on the balance are recorded.

More liquid is added and a second pair of readings is recorded.

The table shows the two pairs of readings.

<i>reading on measuring cylinder / cm³</i>	<i>reading on balance / g</i>
10.0	15.0
25.0	27.6

What is the density of the material from which the powder is made?

- A 0.414 g cm⁻³
- B 1.16 g cm⁻³
- C 1.31 g cm⁻³
- D 1.45 g cm⁻³
- E 2.00 g cm⁻³
- F 2.50 g cm⁻³
- G 3.48 g cm⁻³
- H 6.00 g cm⁻³

- 18** A stone of mass 100 g is fired horizontally from an 80 m high vertical cliff. The ground below the cliff is horizontal.

The kinetic energy of the stone when it hits the ground is 125 J.

What is the distance from the bottom of the cliff to the point where the stone hits the ground?

(gravitational field strength = 10 N kg^{-1} ; ignore air resistance and any effect of wind)

- A** 60 m
- B** 80 m
- C** 120 m
- D** 160 m
- E** 200 m

- 19** An electrical component is connected to a switch and a power supply which has a constant terminal potential difference V . The switch is initially open. At time $t = 0$ the switch is closed.

When the switch is closed, the current I in the component increases with time t as given by the equation

$$I = kt^2$$

where k is a positive constant.

When the current reaches a value I_F the component fails and the current falls instantly to zero.

How much electrical energy has been transferred to the component by the time it fails?

(All quantities are in standard SI units.)

A $\frac{Vk}{3} \left(\frac{I_F}{k} \right)^{\frac{3}{2}}$

B $Vk \left(\frac{I_F}{k} \right)^{\frac{3}{2}}$

C $3Vk \left(\frac{I_F}{k} \right)^{\frac{3}{2}}$

D $\frac{Vk}{3} \left(\frac{I_F}{k} \right)$

E $Vk \left(\frac{I_F}{k} \right)$

F $3Vk \left(\frac{I_F}{k} \right)$

- 20 A water trough has the shape of a prism, with a cross section that is a right-angled isosceles triangle.

One rectangular face and the two triangular ends of the trough are vertical, as shown.

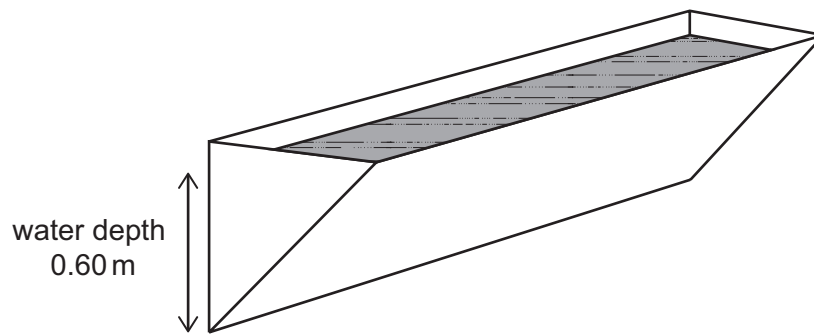

[diagram not to scale]

The trough contains water of depth 0.60 m measured on the vertical rectangular face.

What is the force exerted by the water on one triangular end of the trough?

(density of water = 1000 kg m^{-3} ; gravitational field strength = 10 N kg^{-1})

- A 180 N
- B 270 N
- C 360 N
- D 540 N
- E 720 N
- F 1080 N
- G 6000 N
- H 12000 N

BLANK PAGE

PART Y Chemistry

- 21** A Group 1 metal hydrogencarbonate contains the HCO_3^- ion and decomposes at 200°C .

When dilute hydrochloric acid is added to the residue from the thermal decomposition of this metal hydrogencarbonate, a gas is released that turns limewater cloudy. The residue also gives a yellow-orange colour in a flame test.

8.4 g of this metal hydrogencarbonate is heated to constant mass at 200°C .

How much mass is lost in this reaction?

(A_r values: H = 1; C = 12; O = 16; Li = 7; Na = 23; K = 39)

- A** 2.2 g
- B** 2.6 g
- C** 3.1 g
- D** 4.0 g
- E** 4.4 g
- F** 5.3 g
- G** 6.2 g

- 22 Which of the following statements is correct for the bond angle (θ) in gaseous germanium(II) chloride, GeCl_2 , molecules as predicted by the VSEPR model?
- A $\theta = 90^\circ$
 - B $90^\circ < \theta < 120^\circ$
 - C $\theta = 120^\circ$
 - D $120^\circ < \theta < 180^\circ$
 - E $\theta = 180^\circ$

- 23** Propanal can be reduced to propan-1-ol with hydrogen gas at high pressure and a platinum catalyst.

Radioactive propan-1-ol can be made if the hydrogen gas is replaced by pure tritium gas. Tritium, ^3H , is the radioactive isotope of hydrogen.

All of the atoms other than ^3H in the radioactive propan-1-ol are the most abundant isotope for the element. The most abundant isotopes of carbon, hydrogen and oxygen are ^{12}C , ^1H and ^{16}O .

How many neutrons are there in one molecule of this radioactive propan-1-ol?

- A** 26
- B** 28
- C** 30
- D** 32
- E** 34
- F** 40
- G** 42

- 24** A sample of hydrated cobalt(II) sulfate, $\text{CoSO}_4 \cdot x\text{H}_2\text{O}$, with a mass of 5.62 g, was heated to convert the sample completely to 3.10 g of anhydrous cobalt(II) sulfate.

What is the value of x ?

(A_r values: H = 1.0; O = 16.0; S = 32.1; Co = 58.9)

- A** 2
- B** 3
- C** 4
- D** 5
- E** 6
- F** 7
- G** 8
- H** 9

25 Which of the following does **not** give the species shown?

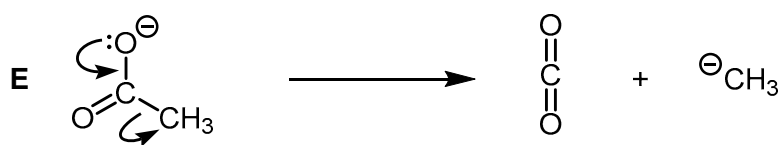
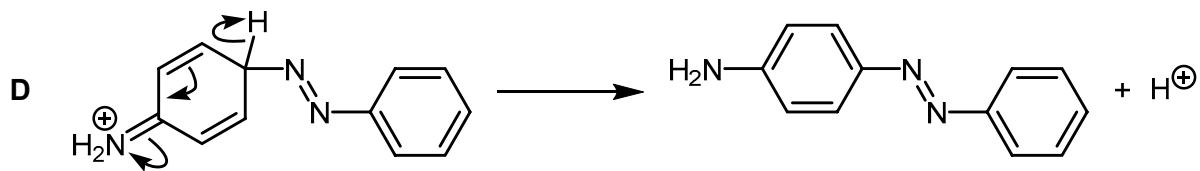
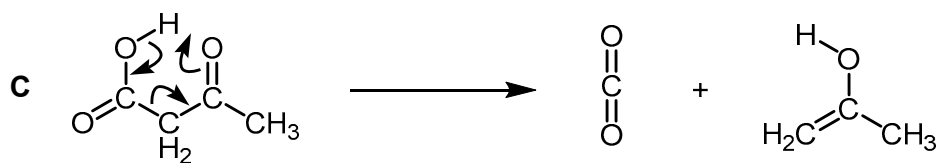
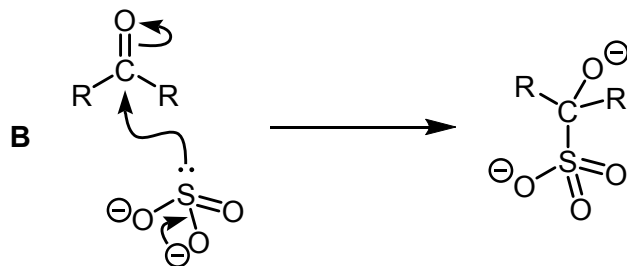
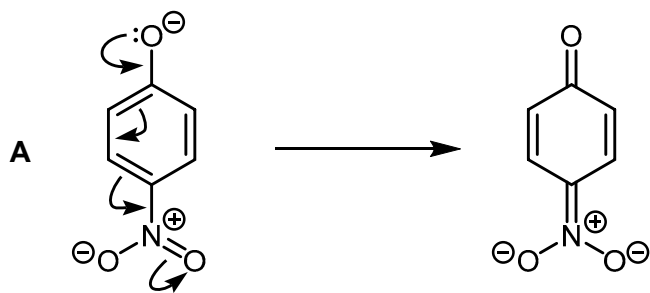

- 26** 0.4 mol of a halogenoalkane reacted completely with hot, ethanolic potassium hydroxide to give 28 g of a single organic product X in 100% yield.

What percentage of all of the structural isomers with both the same functional group and molecular formula as X would show geometric (*E/Z*) isomerism?

(A_r values: H = 1; C = 12)

- A** 17%
- B** 20%
- C** 25%
- D** 33%
- E** 40%
- F** 50%

27 25.0 cm³ of sodium hydroxide solution is placed in a polystyrene cup with a thermometer.

1.00 mol dm⁻³ hydrochloric acid is added from a burette to the stirred solution of sodium hydroxide.

Both solutions are at the same temperature before mixing.

The temperature is recorded each time a measured amount of hydrochloric acid is added, and the data is plotted on a graph.

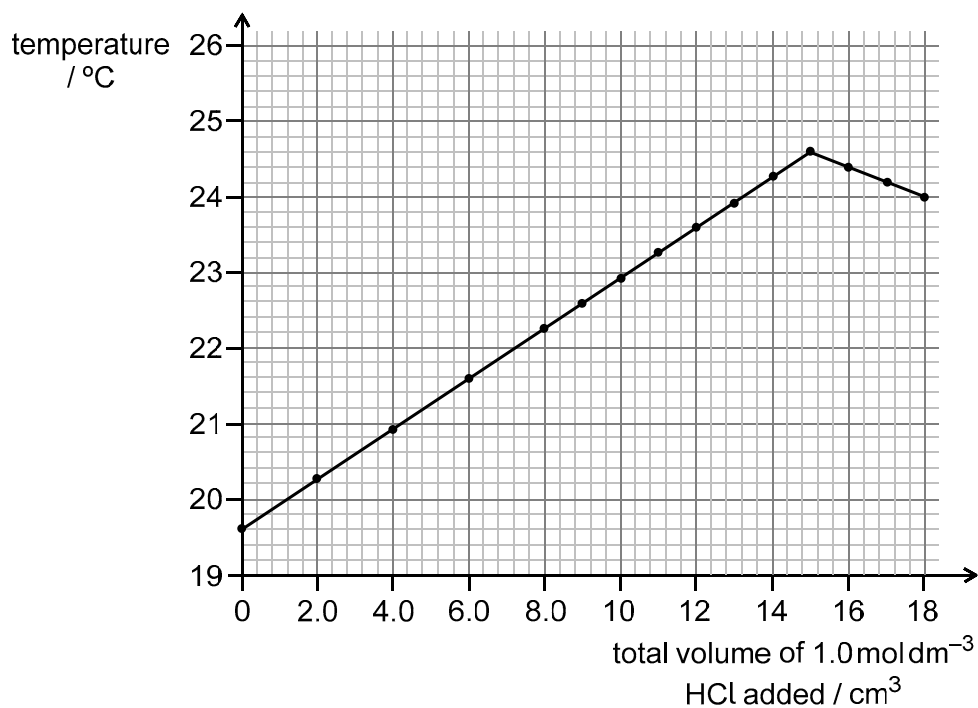

Assuming that no heat is lost from the cup, what is the enthalpy change of reaction when one mole of aqueous sodium hydroxide is neutralised?

(Assume that all solutions have density 1.0 g cm⁻³ and specific heat capacity 4.2 J g⁻¹ °C⁻¹.)

- A -56.0 kJ
- B -49.3 kJ
- C -35.0 kJ
- D -33.6 kJ
- E -21.0 kJ

- 28 Consider the distribution of a solute X between two immiscible solvents: water and ether.

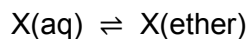

The equilibrium constant, K_c , is 0.15 at 25 °C.

50 cm³ of a solution of X in ether at 25 °C contains 21.5 g of X. 100 cm³ of water is added, shaken with the ether solution and allowed to reach equilibrium at 25 °C.

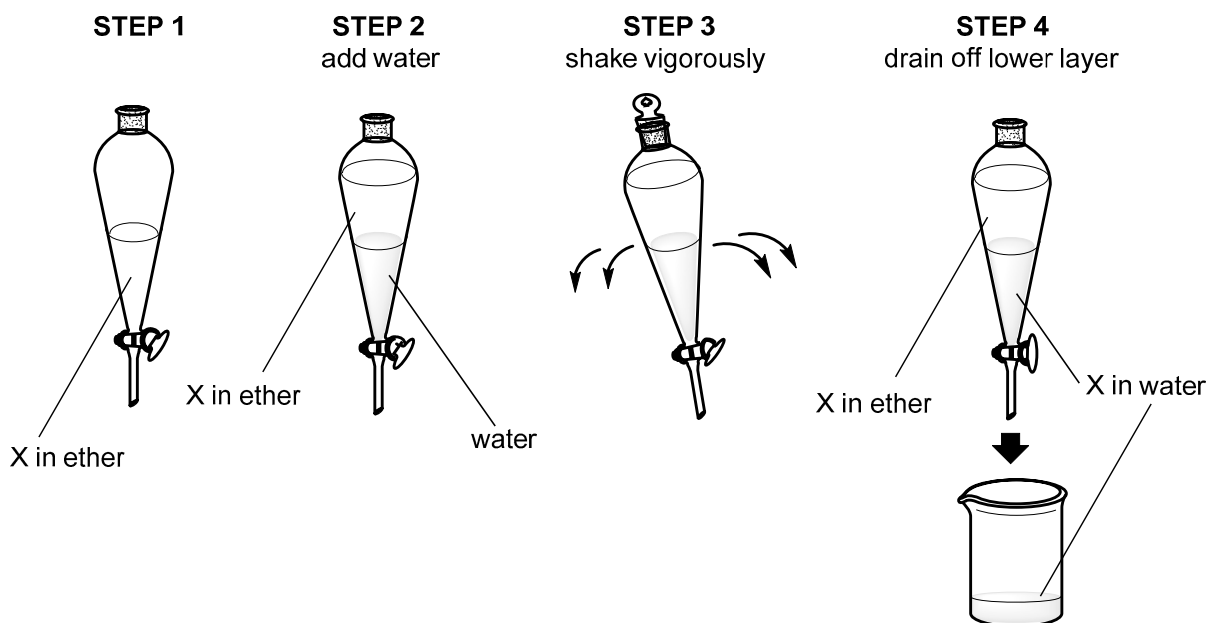

What is the maximum mass of X that can be transferred into the aqueous layer?

- A 4.96 g
- B 14.3 g
- C 18.7 g
- D 20.0 g
- E 20.5 g

29

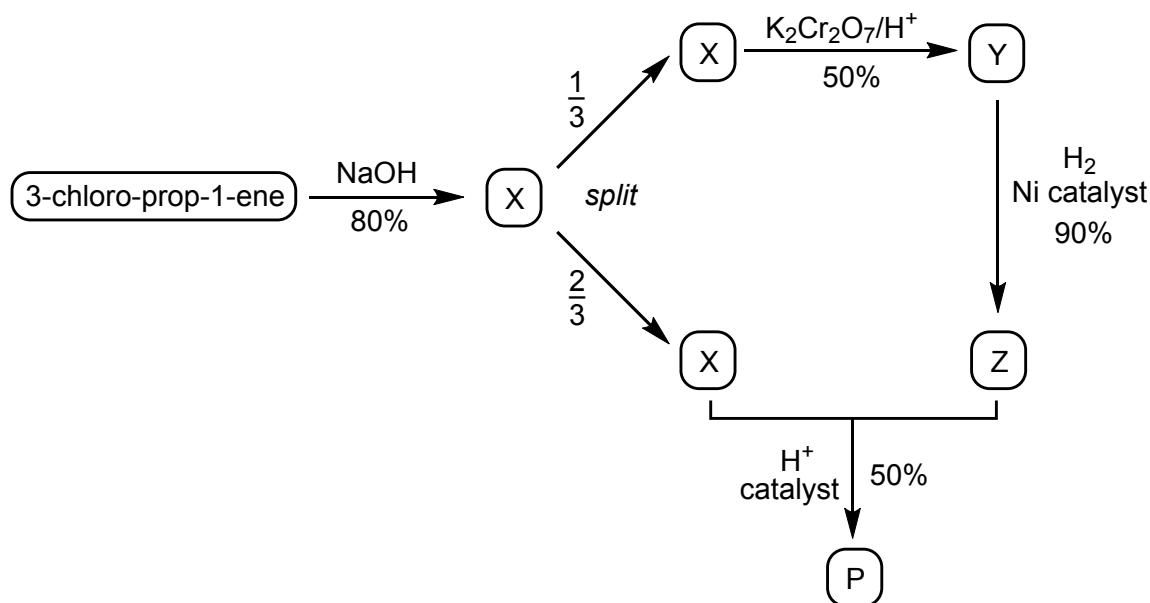

5.0 mol of 3-chloro-prop-1-ene ($M_r = 76.5$) was reacted with excess sodium hydroxide to form a single product X in 80% yield.

One third of compound X was heated with excess acidified potassium dichromate(VI) under reflux to form a single product Y in 50% yield.

All of compound Y was reacted with hydrogen gas at high temperature in the presence of nickel to form a single product Z in 90% yield.

The remaining quantity of compound X was reacted with all of compound Z in the presence of an acid catalyst to form product P in 50% yield.

What is the maximum mass of product P that could be produced from this synthesis?

(A_r values: H = 1; C = 12; O = 16; Cl = 35.5)

- A 2.74 g
- B 5.48 g
- C 23.0 g
- D 34.2 g
- E 114 g
- F 123 g
- G 152 g

- 30** Iron(II) sulfate is used as a moss treatment on lawns and sports pitches. The recommended amount of iron is 2.5 kg per 10^4 m^2 .

Analysis of a particular sports pitch showed it to contain 0.05 g of iron per m^2 .

A pitch care company supplies three hydrated formulations:

- $\text{FeSO}_4 \cdot 7\text{H}_2\text{O}$ which contains 20% of iron by mass
- $\text{FeSO}_4 \cdot 4\text{H}_2\text{O}$ which contains 25% of iron by mass
- $\text{FeSO}_4 \cdot \text{H}_2\text{O}$ which contains 33% of iron by mass

A 25 kg sack of one of the iron(II) sulfate formulations is to be used on the sports pitch but unfortunately it has lost its label. A small sample was heated to constant mass to form a white solid, and the mass of the sample decreased by more than 40% in this process.

The sports pitch is 90 m long and 60 m wide.

What mass of the iron(II) sulfate formulation (in kg) should be added to ensure that the iron content is at the recommended level?

(M_r values: $\text{FeSO}_4 = 152$; $\text{H}_2\text{O} = 18$)

- A** 1.08 kg
- B** 1.35 kg
- C** 3.60 kg
- D** 4.32 kg
- E** 5.40 kg
- F** 6.75 kg

- 31** A compound contains potassium cations, and anions that contain only boron and fluorine. Each anion contains one boron atom.

0.630 g of this compound contains 0.195 g of potassium and 0.055 g of boron.

What is the shape of the anions in this compound?

(A_r values: B = 11; F = 19; K = 39)

- A** linear
- B** bent (V-shaped)
- C** trigonal planar
- D** trigonal pyramidal
- E** tetrahedral
- F** square planar

32 The first ionisation energy of five elements is measured.

Which row matches the five elements to their first ionisation energy?

<i>first ionisation energy / kJ mol⁻¹</i>					
	577	736	1000	1060	1680
A	F	Mg	Al	P	S
B	F	P	S	Mg	Al
C	F	P	S	Al	Mg
D	Mg	Al	S	P	F
E	Mg	Al	P	S	F
F	Al	Mg	P	S	F
G	Al	Mg	S	P	F
H	S	P	Al	Mg	F

- 33** A yellow precipitate is formed when alkaline aqueous iodine reacts with alcohols that have the structure $R-CH(OH)CH_3$, where R is a carbon chain or H.

There are a number of structural isomers with the molecular formula $C_5H_{12}O$ that are alcohols.

Of these structural isomeric alcohols:

- (i) how many will form a yellow precipitate when reacted with alkaline aqueous iodine;
- (ii) how many, following mild oxidation and immediate distillation, will produce a silver mirror with Tollens' reagent?

	(i) <i>forms yellow precipitate</i>	(ii) <i>produces silver mirror</i>
A	1	1
B	2	3
C	2	4
D	2	7
E	3	3
F	3	4
G	3	7
H	4	4

- 34 The standard enthalpy change of formation of hydrogen iodide is $+26 \text{ kJ mol}^{-1}$.

For the reaction of gaseous iodine with hydrogen

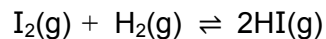

the enthalpy change of reaction can be calculated using bond enthalpy values.

The bond enthalpies are:

<i>bond</i>	<i>bond enthalpy / kJ mol^{-1}</i>
H–H	436
I–I	151
H–I	299

The sublimation of iodine is represented by: $\text{I}_2(\text{s}) \rightarrow \text{I}_2(\text{g})$

Using the data provided, what is the enthalpy change for the sublimation of iodine?

(All data is given at room temperature and pressure.)

- A -262 kJ mol^{-1}
- B -236 kJ mol^{-1}
- C -41 kJ mol^{-1}
- D $+37 \text{ kJ mol}^{-1}$
- E $+41 \text{ kJ mol}^{-1}$
- F $+63 \text{ kJ mol}^{-1}$
- G $+236 \text{ kJ mol}^{-1}$

- 35** Sodium hydrogencarbonate, NaHCO_3 , and sodium carbonate are both used as antacids. They react with hydrochloric acid in the stomach to form the same products.

The contents of a person's stomach has a pH of 1.0, which is a concentration of 0.1 mol dm^{-3} HCl. The stomach contained 80 cm^3 of aqueous solution when the pH was measured.

Which of the following amounts of sodium hydrogencarbonate would bring the stomach contents into the normal range of pH 2.0-3.0?

(A_r values: H = 1; C = 12; O = 16; Na = 23)

- A** 0.0038 mol
- B** 0.0075 mol
- C** 0.0080 mol
- D** 0.016 mol
- E** 0.095 mol

- 36** X is a dicarboxylic acid. When in aqueous solution, 2.36 g of X reacts with excess sodium carbonate to produce 480 cm^3 of carbon dioxide, measured at room temperature and pressure. Assume that no gas dissolves in the water present.

Y is a liquid organic compound containing only one functional group. 1 mol of Y reacts exactly with 1 mol of sodium, giving off a gas that pops with a lighted splint. Aqueous Y does not change the colour of blue or red litmus papers.

When 50.0 cm^3 of gaseous Y is combusted in excess oxygen, 150 cm^3 of carbon dioxide and 200 cm^3 of water vapour are the only products formed. All volumes are measured at the same temperature and pressure.

When heated in the presence of concentrated sulfuric acid, 1 mol of X reacts completely with 2 mol of Y to give 1 mol of organic product Z. Water is also produced in the reaction.

What is the relative molar mass of Z?

(A_r values: H = 1; C = 12; O = 16. Assume that one mole of gas occupies 24 dm^3 at room temperature and pressure.)

- A 101
- B 160
- C 166
- D 170
- E 202
- F 220

- 37 Cats are unable to synthesise the amino acid taurine in their bodies, so they must obtain it from their food. It is often added to cat food as an additive.

Taurine is a monoprotic acid with the following molecular structure:

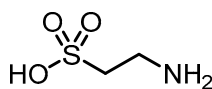

$$M_r = 125$$

Dietary studies suggest that a cat should consume 10 mg of taurine per kilogram of body mass per day.

Brand X cat food contains taurine at a level of 0.008% by mass, but this level is too low for a cat to acquire a sufficient amount from a healthy amount of food.

Magnesium taurate is an ionic salt which liberates taurine in the body. 8 cm³ of a 0.5 mol dm⁻³ aqueous solution of magnesium taurate was added to a 10 kg bag of brand X cat food and thoroughly mixed.

A particular cat bowl can hold a 50 g serving of cat food. A particular cat of mass 4000 g always eats a full serving.

What is the minimum number of bowls of cat food that this cat must eat to ensure that it has consumed its daily requirement of taurine?

(Assume that the addition of the solution does not significantly alter the total mass of the bag of cat food.)

- A 2
- B 3
- C 4
- D 5
- E 6
- F 7
- G 8

- 38** Analysis of hydrocarbon P showed it to contain 0.60 g of carbon and 0.10 g of hydrogen, and to have a relative molecular mass of 70.

P reacts with hydrogen bromide to form a mixture of Q and R. However, the main product was Q.

Q reacts with warm, aqueous sodium hydroxide to form S.

S reacts with warm, acidified potassium dichromate(VI) to form T. T does not produce a silver mirror with Tollens' reagent and does not produce bubbles when sodium carbonate is added.

S undergoes dehydration on reaction with hot, concentrated sulfuric acid to form the original hydrocarbon P and a new compound U. Both P and U do not have stereoisomers.

What is the structure of compound U?

(A_r values: H = 1; C = 12)

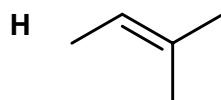
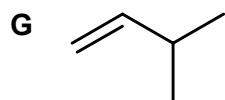
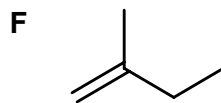
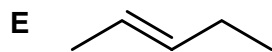
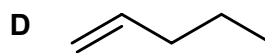
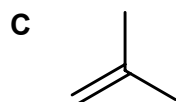
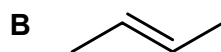
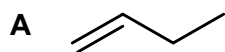

- 39 Lanthanum iodate(V), $\text{La}(\text{IO}_3)_3$, decomposes when heated to 600°C to give a product that contains the ion Q.

An **unbalanced** ionic equation for the reaction is:

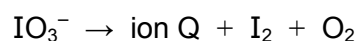

Ion Q contains only iodine in the +7 oxidation state and oxygen in the -2 oxidation state.

The oxidation state of the lanthanum does not change in the reaction.

0.005 mol of $\text{La}(\text{IO}_3)_3$ is fully decomposed by heating. The iodine produced is titrated against a 0.4 mol dm^{-3} solution of sodium thiosulfate ($\text{Na}_2\text{S}_2\text{O}_3$). 30.0 cm^3 of the sodium thiosulfate solution is needed to reach the end-point. The equation for the reaction between iodine and sodium thiosulfate is:

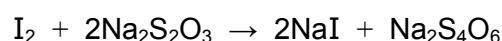

What is the formula of the product that contains ion Q?

- A LaIO_5
- B LaIO_6
- C $\text{La}(\text{IO}_4)_3$
- D $\text{La}_3(\text{IO}_6)_5$
- E $\text{La}_5(\text{IO}_4)_3$
- F $\text{La}_5(\text{IO}_6)_3$

40 Consider the following chemical equation:

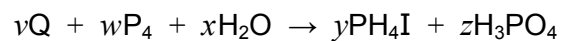

where Q is a binary compound.

The molecules of Q are hexatomic and contain phosphorus in the +2 oxidation state.

Using the lowest integer values for all the coefficients v , w , x , y and z , what is the value of w when the equation is balanced?

- A 1
- B 2
- C 13
- D 16
- E 24
- F 26

BLANK PAGE

PART Z Biology

- 41** Cystic fibrosis and sickle cell anaemia are both recessive genetic conditions and the genes for these conditions are found on different non-sex chromosomes.

The following statements are true for one set of parents who have only one child:

- Both parents are heterozygous for cystic fibrosis.
- One parent is homozygous recessive for sickle cell anaemia.
- One parent is heterozygous for sickle cell anaemia.

What is the probability of this child having both conditions?

- A** 0.75
- B** 0.5
- C** 0.375
- D** 0.25
- E** 0.125
- F** 0.0625

- 42 The diagram shows a food chain. The numbers represent energy available and are in arbitrary units (a.u.), and the percentages represent efficiency of energy transfer.

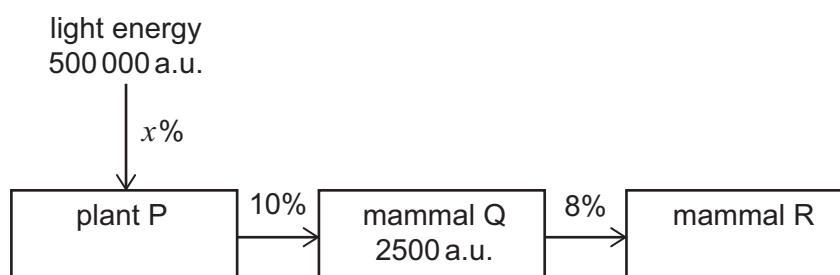

The energy transfer between trophic levels is not 100% efficient.

Which row is correct for this food chain?

	<i>efficiency of energy transfer x</i>	<i>a reason for inefficiency of energy transfer from Q to R</i>
A	1%	energy lost as heat
B	1%	cellulose not digested
C	1%	some wavelengths of light not used
D	5%	energy lost as heat
E	5%	cellulose not digested
F	5%	some wavelengths of light not used

- 43** A number of patients in a hospital were infected with the same bacterial pathogen. The symptoms of this infection included pain in the abdomen, sickness and loss of appetite partly resulting from decreased production of acid in the stomach.

The bacteria present in their digestive systems were compared with those of healthy volunteers.

Samples were taken from each person and examined in order to identify the type of bacteria present and their relative proportions.

The results of the study are shown in the chart.

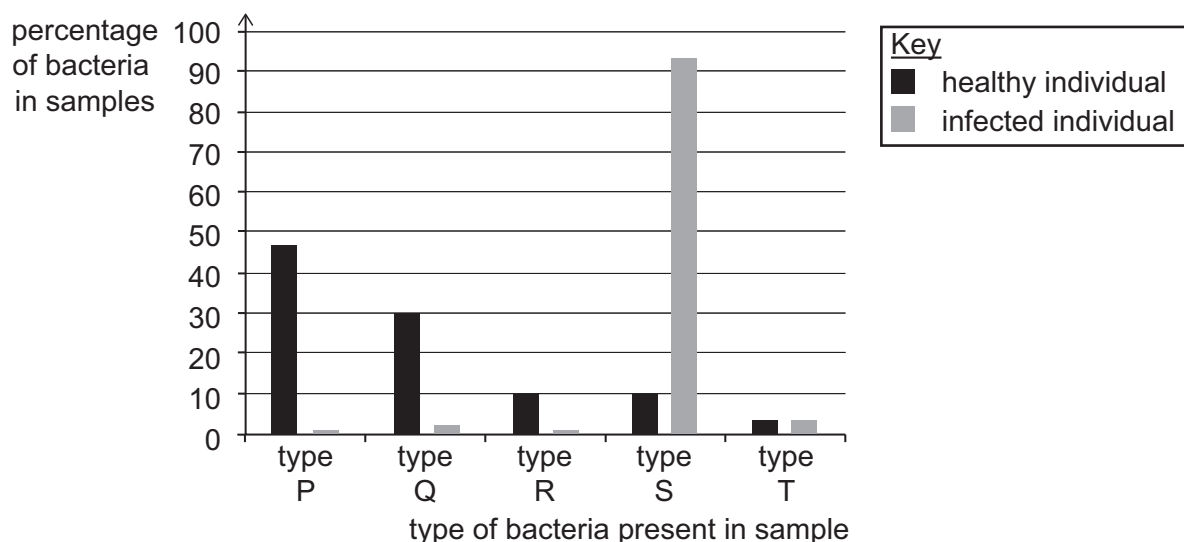

Which of the following statements could be correct?

- 1 Type S and type T feed on different biological molecules.
 - 2 The DNA sequence of bacterial genes was used to classify the bacteria.
 - 3 Type P, type Q and type R reduce in number because they require an alkaline environment.
- A** none of them
- B** 1 only
- C** 2 only
- D** 3 only
- E** 1 and 2 only
- F** 1 and 3 only
- G** 2 and 3 only
- H** 1, 2 and 3

- 44 A scientist studied one species of plant and grew some at 20 °C (plants P) and some at 30 °C (plants Q). All other variables were kept constant.

The scientist then placed plants from each group into six separate temperature-controlled cabinets, each at a different temperature. The plants were left for 15 minutes to adjust to their new temperature. The scientist then measured the rate of net carbon dioxide uptake by the leaves on the plants. All other variables were kept constant.

The results are shown in the graph.

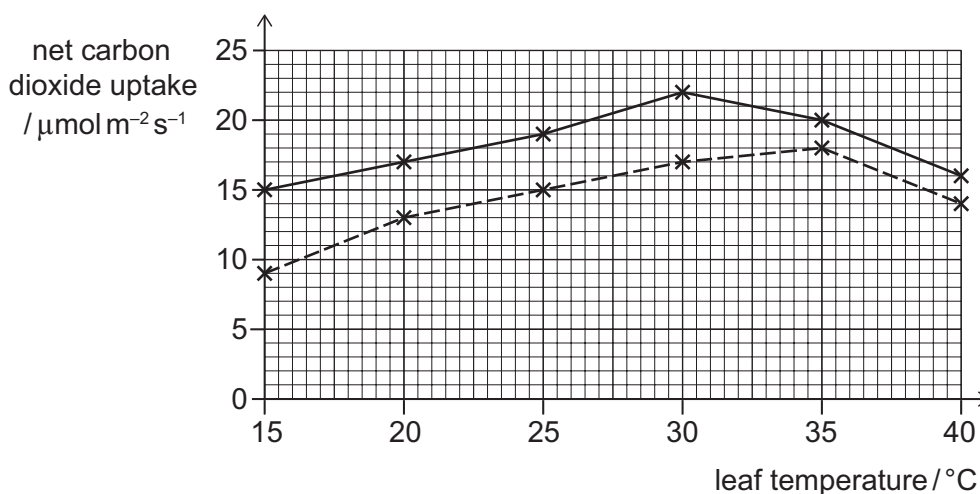
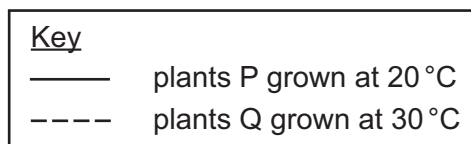

Which of the following statements is/are correct?

- 1 At 35 °C, a 200 cm² leaf of plant P would take up 1.44×10^7 μmol of carbon dioxide in one hour.
 - 2 Assuming that their respiration rates are the same, the rate of oxygen production in a leaf from plant P at 20 °C will be approximately equal to that in a leaf of the same size from plant Q at 30 °C.
 - 3 The optimum temperature for maximum rate of photosynthesis in plant P must be 30 °C.
- A** none of them
- B** 1 only
- C** 2 only
- D** 3 only
- E** 1 and 2 only
- F** 1 and 3 only
- G** 2 and 3 only
- H** 1, 2 and 3

- 45** A group of scientists studied the effect of droughts on the reproduction rate and lifespan of different species of birds.

The graph shows their results. Each data point refers to a different species.

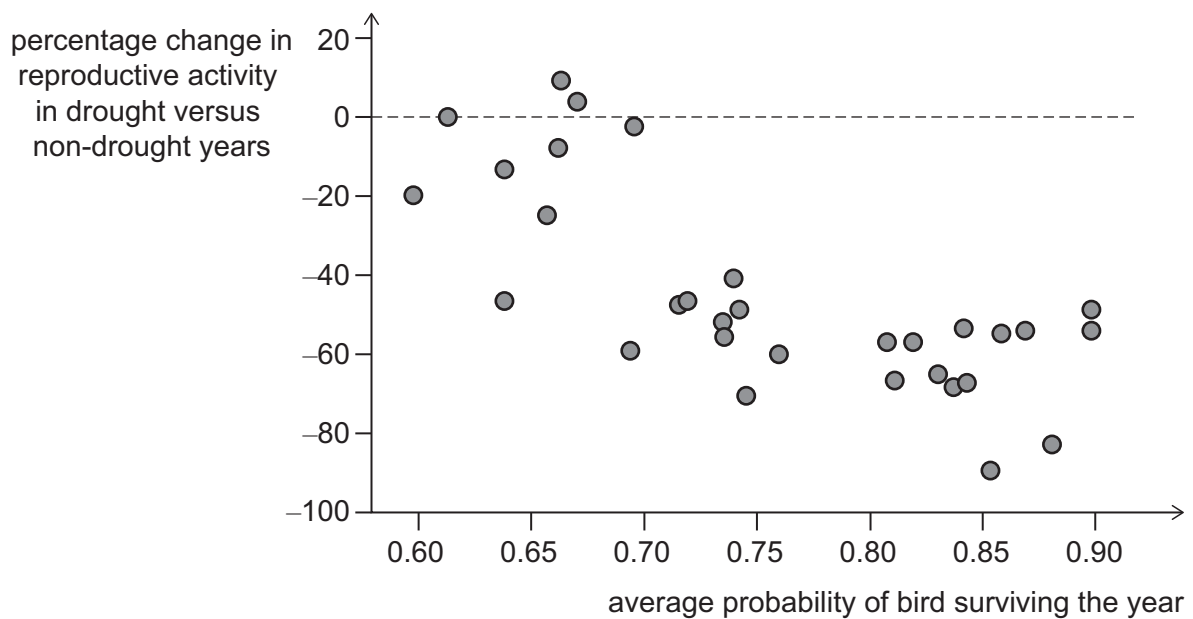

Which of these statements is/are correct?

- 1** The overall trend for this data shows that birds with shorter life expectancies tended to change their reproduction rates less in drought years.
 - 2** Some birds were found to reproduce more in drought years than in non-drought years.
 - 3** These birds were being studied for the effect of a biotic factor on their population size.
- A** none of them
- B** 1 only
- C** 2 only
- D** 3 only
- E** 1 and 2 only
- F** 1 and 3 only
- G** 2 and 3 only
- H** 1, 2 and 3

- 46** The average volume of a mammalian mitochondrion is $0.5 \mu\text{m}^3$. The density of the enzymes within the mitochondria is 450 mg of enzymes per mm^3 of mitochondrial volume.

What is the mass, in mg, of enzyme inside an average mammalian mitochondrion, and how would a decrease in enzyme density within all mitochondria inside a cell change the rate of anaerobic respiration in the cell as a whole?

(Assume that the overall metabolic rate of the cell remains constant.)

	<i>mass of enzyme inside an average mammalian mitochondrion / mg</i>	<i>change in the rate of anaerobic respiration in the cell as a whole that may occur if the enzyme density decreases</i>
A	2.25×10^{-7}	decreases
B	2.25×10^{-7}	increases
C	2.25×10^{-3}	decreases
D	2.25×10^{-3}	increases
E	2.25×10^{-1}	decreases
F	2.25×10^{-1}	increases
G	2.25×10^2	decreases
H	2.25×10^2	increases

- 47 At a certain time, the percentage of oxygen carried in the blood entering the right atrium is 40% of its maximum capacity.

At this time, a section of a human pulmonary artery is 5 cm long and has a lumen diameter of 2.8 mm.

Another artery in the human body is the renal artery.

What is the volume of blood in this pulmonary artery section, and the oxygen level in the blood in the renal artery, at this time?

	<i>volume of blood in the lumen of this pulmonary artery section / mm³</i>	<i>percentage of oxygen carried in the blood in the renal artery</i>
A	$5 \times (0.14)^2 \times \pi$	less than 40%
B	$50 \times (1.4)^2 \times \pi$	less than 40%
C	$2.8 \times (25)^2 \times \pi$	less than 40%
D	$5 \times (0.14)^2 \times \pi$	40%
E	$50 \times (1.4)^2 \times \pi$	40%
F	$5 \times (0.14)^2 \times \pi$	greater than 40%
G	$50 \times (1.4)^2 \times \pi$	greater than 40%
H	$2.8 \times (25)^2 \times \pi$	greater than 40%

- 48** A 1 cm^3 sample of blood was taken from an infected patient. This sample was added to saline solution to make a total volume of 50 cm^3 .

This diluted sample was then viewed using a haemocytometer, a special microscope slide that allows the number of blood cells in a known volume to be counted. The volume analysed using the haemocytometer was $1.0 \times 10^{-4} \text{ cm}^3$.

The type and number of cells counted is shown.

<i>cell type</i>	<i>number of cells</i>
mature red blood cell	12
white blood cell	4
bacterial cell	5

Using this data only, how many cells with nuclei were present in the 1 cm^3 sample from the patient?

- A** 4.0×10^4
- B** 9.0×10^4
- C** 1.6×10^5
- D** 2.0×10^6
- E** 4.5×10^6
- F** 6.0×10^6
- G** 8.0×10^6
- H** 1.05×10^7

- 49** The oxygen saturation of red blood cells is the percentage of haemoglobin binding sites in red blood cells with oxygen bound to them.

Camels and llamas have evolved from the same ancestor. Camels live at low altitude and llamas live at high altitude.

The graph shows the effect of oxygen concentration on the oxygen saturation of red blood cells in camels and llamas.

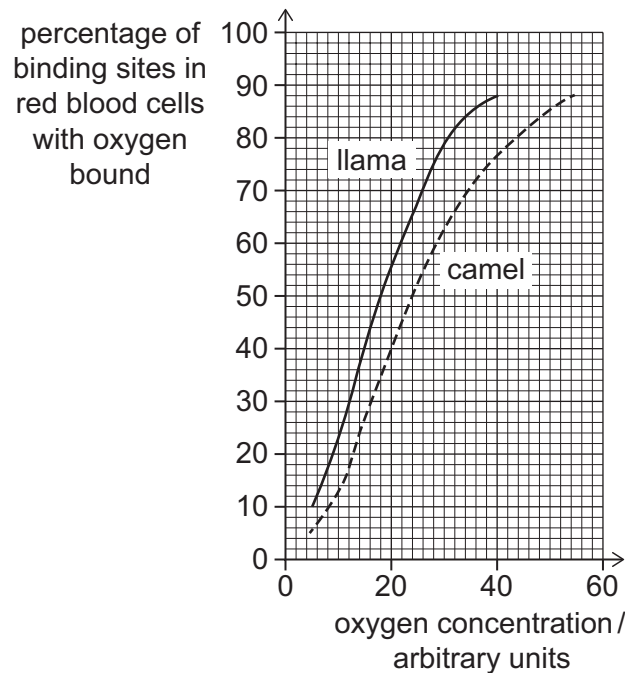

Which of the following statements is/are correct?

- 1** The difference in oxygen binding properties of the red blood cells of camels and llamas is an example of different phenotypes.
 - 2** The different oxygen binding properties evolved because of mutations caused by different oxygen concentrations.
 - 3** 50% oxygen saturation of llama red blood cells occurs at $\frac{3}{4}$ of the oxygen concentration required for 50% oxygen saturation of camel red blood cells.
- A** none of them
- B** 1 only
- C** 2 only
- D** 3 only
- E** 1 and 2 only
- F** 1 and 3 only
- G** 2 and 3 only
- H** 1, 2 and 3

- 50** Water in a particular plant moves from a high water potential to a low (more negative) water potential. Water potential is measured in MPa.

Which row correctly describes the most direct pathway for water movement into, through, and out of this plant?

	<i>water potential in soil / MPa</i>	<i>water potential in plant root / MPa</i>	<i>tissue in plant for water transport</i>	<i>water potential in leaf / MPa</i>	<i>water potential in atmosphere / MPa</i>	<i>a mechanism for water leaving the leaf</i>
A	-75	-1.5	xylem	-0.1	-0.033	diffusion
B	-0.033	-0.1	xylem	-1.5	-75	diffusion
C	-0.033	-0.1	phloem	-1.5	-75	diffusion
D	-75	-1.5	phloem	-0.1	-0.033	osmosis
E	-1.5	-75	phloem	-0.033	-0.1	osmosis
F	-0.033	-0.1	xylem	-1.5	-75	osmosis

51 On a cool spring day (day 1), a healthy human produces 1500 cm^3 of urine.

The concentration of urea in the urine was measured as $2.00 \text{ g per } 100 \text{ cm}^3$.

On a similar day (day 2), the same person plays a game of hockey and produces 20% less urine. However, the mass of urea excreted in the urine remains the same.

The volume of urine produced is affected by the movement of water in the nephron.

Which row shows the urea concentration in the urine, in g dm^{-3} , on day 1 and day 2, and the explanation for the change in urine volume?

	<i>urea concentration / g dm^{-3}</i>		<i>explanation for change in urine volume</i>	
	<i>day 1</i>	<i>day 2</i>	<i>change in ADH (vasopressin)</i>	<i>change in water movement in the nephron</i>
A	20.0	16.7	decrease	decrease in secretion of water
B	20.0	16.7	increase	increase in reabsorption of water
C	20.0	25.0	decrease	decrease in secretion of water
D	20.0	25.0	increase	increase in reabsorption of water
E	30.0	25.0	decrease	decrease in secretion of water
F	30.0	25.0	increase	increase in reabsorption of water
G	30.0	36.0	decrease	decrease in secretion of water
H	30.0	36.0	increase	increase in reabsorption of water

52 A scientist conducts an experiment to study a single-celled organism in a growth tube.

The organism divides once every 50 minutes using binary fission. Binary fission produces the same number of daughter cells per division as a cell dividing by mitosis.

The scientist starts with 150 cells. The experiment is left for 300 minutes.

The average volume of every cell is $5 \mu\text{m}^3$.

To ensure there are sufficient nutrients available for the cells, the final volume of cells within the tube must not be more than 1% of the total volume of material inside the tube.

What is the minimum volume of nutrient solution required inside the growth tube at the start of the experiment?

(Assume that all the cells are alive and capable of dividing.)

A $4.8 \times 10^{-3} \text{ mm}^3$

B $9.5 \times 10^{-3} \text{ mm}^3$

C $3.1 \times 10^{-1} \text{ mm}^3$

D $4.8 \times 10^{-1} \text{ mm}^3$

E $9.5 \times 10^{-1} \text{ mm}^3$

F $9.5 \times 10^2 \text{ mm}^3$

G $4.8 \times 10^3 \text{ mm}^3$

H $3.1 \times 10^5 \text{ mm}^3$

- 53** Sex determination in cows is identical to that in humans. To maximise productivity, dairy farmers want their cows to have female calves only.

Sperm cells can be sorted using their DNA content. This method is used to ensure the sex of calves born to dairy cows following artificial insemination. The method used is described below:

- The sperm cells are treated with a DNA binding dye.
- The greater the DNA content, the brighter the binding dye fluoresces.
- The brighter sperm cells are given a positive charge and the remaining sperm cells are given a negative charge.
- The charged sperm cells pass through a pair of charged plates and are attracted to the plate with the opposite charge.
- The sperm cells are collected in beakers below the plates.

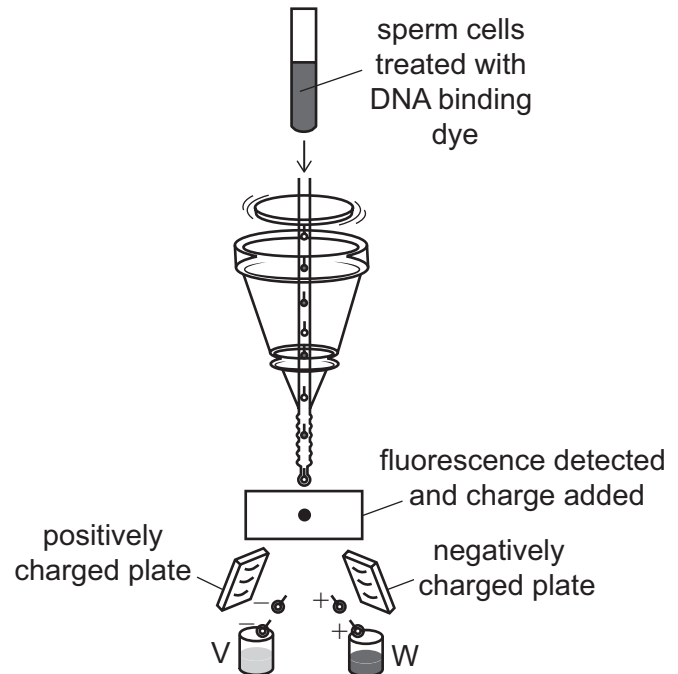

Assume that all the separated sperm cells are alive and capable of fertilisation, no mutations have occurred, and the method of separation is 100% efficient.

Which of the following statements is/are correct?

- 1 Sperm cells in beaker V have fewer chromosomes.
 - 2 For maximum productivity, dairy farmers should only use positively charged sperm cells.
 - 3 The chance of obtaining a female calf using sperm cells from beaker W will be double that of using unseparated sperm cells.
- A** none of them
- B** 1 only
- C** 2 only
- D** 3 only
- E** 1 and 2 only
- F** 1 and 3 only
- G** 2 and 3 only
- H** 1, 2 and 3

- 54** In a sample of four healthy human cells, three rounds of division occur. After the three divisions, there are a total of 1472 chromosomes present in the sample.

The diploid number in human cells is 46.

Which of the following statements about this sample is/are correct?

- 1** The cells could all be fertilised eggs that divided by mitosis only.
 - 2** The cell divisions could be two rounds of mitosis and then one round of complete meiosis.
 - 3** If a single mutation occurred in one allele just before the second division in one cell, then the final percentage of the cells with this mutation would be 12.5%.
- A** none of them
- B** 1 only
- C** 2 only
- D** 3 only
- E** 1 and 2 only
- F** 1 and 3 only
- G** 2 and 3 only
- H** 1, 2 and 3

- 55** Samples of solution removed from different positions inside a nephron are analysed.

The rate of flow of the solution through the nephron is measured at each position where the samples are taken.

The rate of flow is the volume of solution passing a particular point per unit time.

In the Bowman's capsule, the concentration of sodium ions is the same as in the blood. The rate of flow is 100 arbitrary units.

At the collecting duct, the concentration of sodium ions is twice that in the blood. The rate of flow is 1 arbitrary unit.

Which row in the table is correct?

	<i>percentage sodium ions reabsorbed in the nephron</i>	<i>a process by which sodium ions can be reabsorbed from the nephron</i>
A	2%	active transport
B	2%	diffusion
C	50%	osmosis
D	50%	diffusion
E	98%	active transport
F	98%	osmosis

- 56** Mutations can occur in the genes coding for some of the enzymes that catalyse respiration reactions. This can result in mitochondria that do not function correctly.

Scientists studying this tested a molecule, T, for its ability to restore the function to these mitochondria in human cells.

The graphs show the rate of oxygen consumption, measured relative to the percentage of healthy mitochondria, and the rate of acidification of the cellular environment, over time.

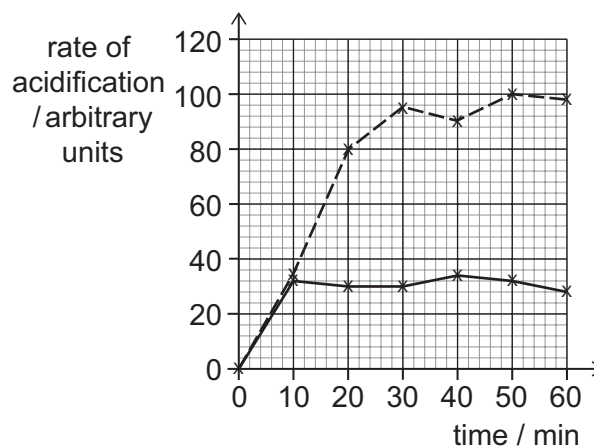
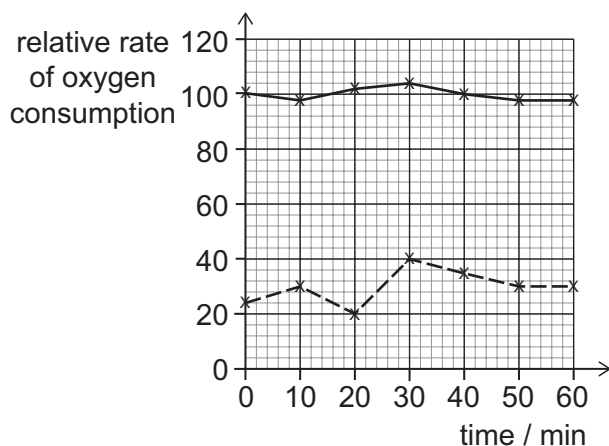
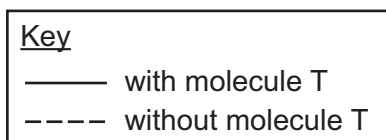

Which of the following statements is/are correct?

- 1 Molecule T could reduce the rate of lactic acid production in the cells.
 - 2 Between 20 and 30 minutes, the oxygen consumption rate without molecule T increases by 50%.
 - 3 The concentration gradient for oxygen between the cell cytoplasm and the mitochondria is steeper with molecule T compared to without molecule T.
- A** none of them
- B** 1 only
- C** 2 only
- D** 3 only
- E** 1 and 2 only
- F** 1 and 3 only
- G** 2 and 3 only
- H** 1, 2 and 3

57 Scientists studied the processes by which drugs cross the cell membrane and enter cells.

The rate of uptake of four drugs, P, Q, R and S, was studied at 4 °C and at 37 °C. The results are shown in the chart. All other variables were kept constant.

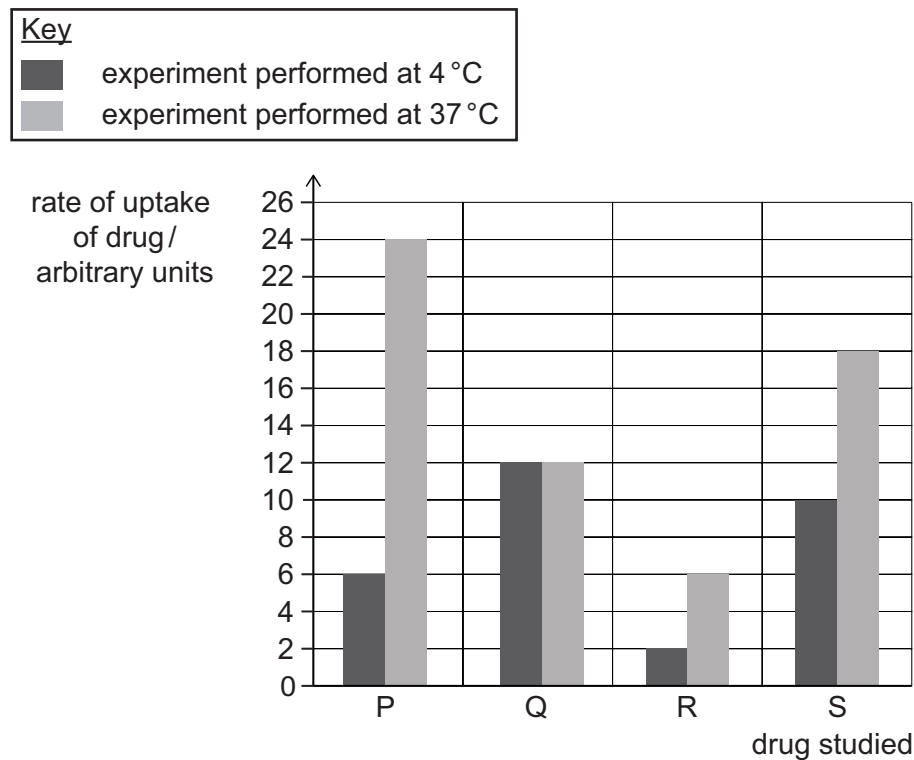

Which of the following conclusions can be drawn from the results?

- 1 The percentage increase in rate of uptake of R from 4 °C to 37 °C is 2.5 times more than the percentage increase in the rate of uptake of S.
- 2 The concentration of Q must be the same inside and outside the cell.
- 3 P must be transported across the cell membrane using active transport only.

- A** none of them
- B** 1 only
- C** 2 only
- D** 3 only
- E** 1 and 2 only
- F** 1 and 3 only
- G** 2 and 3 only
- H** 1, 2 and 3

58 Commercial varieties of tomato are produced from wild varieties of tomato.

The genetic diversity of tomatoes can be measured and expressed as a number.

A population of wild varieties of tomato was found to have a genetic diversity of 0.30.

The table shows the genetic diversity of a population of commercial tomatoes grown at different times.

<i>year</i>	<i>genetic diversity</i>
pre-1960	0.10
1960	0.05
1980	0.20
2000	0.30

Which of the following statements about these tomatoes could be correct?

- 1** Selective breeding of tomatoes occurred before 1960.
- 2** The addition of genetic material, enabling the tomatoes to produce memory cells so that they are resistant to diseases, increased the genetic diversity from 1960 onwards.
- 3** The average rate of increase in genetic diversity per day between 1960 and 2000 is approximately $\frac{25}{1\,460\,000}$.
- 4** The increase in genetic diversity was 50% greater during the 1960 to 1980 period than the 1980 to 2000 period.

- A** 1 and 2 only
- B** 1 and 3 only
- C** 1 and 4 only
- D** 2 and 3 only
- E** 2 and 4 only
- F** 1, 2 and 3 only
- G** 1, 3 and 4 only
- H** 2, 3 and 4 only

- 59** A mathematical test can be used to determine whether there is a statistically significant difference between the expected and the observed number of individuals with each phenotype in a population.

The value required for this test is calculated using the following expression:

$$\frac{(\text{observed} - \text{expected})^2}{\text{expected}} + \dots + \frac{(\text{observed} - \text{expected})^2}{\text{expected}}$$

where each term uses the observed number of individuals and expected number of individuals with each phenotype in turn.

In a monohybrid cross between two individuals that showed the same phenotype, 160 offspring were produced. 36 of these offspring showed a different phenotype to both parents for the same characteristic.

The characteristic is controlled by a single gene with one dominant allele and one recessive allele.

Which of the following expressions calculates the value required for the mathematical test for this cross?

(Assume no mutations and that no genotype results in the death of individuals.)

A $\frac{4}{120} + \frac{4}{40}$

B $\frac{4}{124} + \frac{4}{36}$

C $\frac{16}{120} + \frac{16}{40}$

D $\frac{16}{124} + \frac{16}{36}$

E $\frac{32}{160}$

F $\frac{44}{124} + \frac{44}{36}$

G $\left(\frac{44^2}{80}\right) + \left(\frac{44^2}{80}\right)$

H $\left(\frac{44^2}{124}\right) + \left(\frac{44^2}{36}\right)$

- 60 An investigation was carried out to discover the evolutionary relationships between three different species of mammal, a human, a monkey and a hedgehog, as shown in the flow diagram:

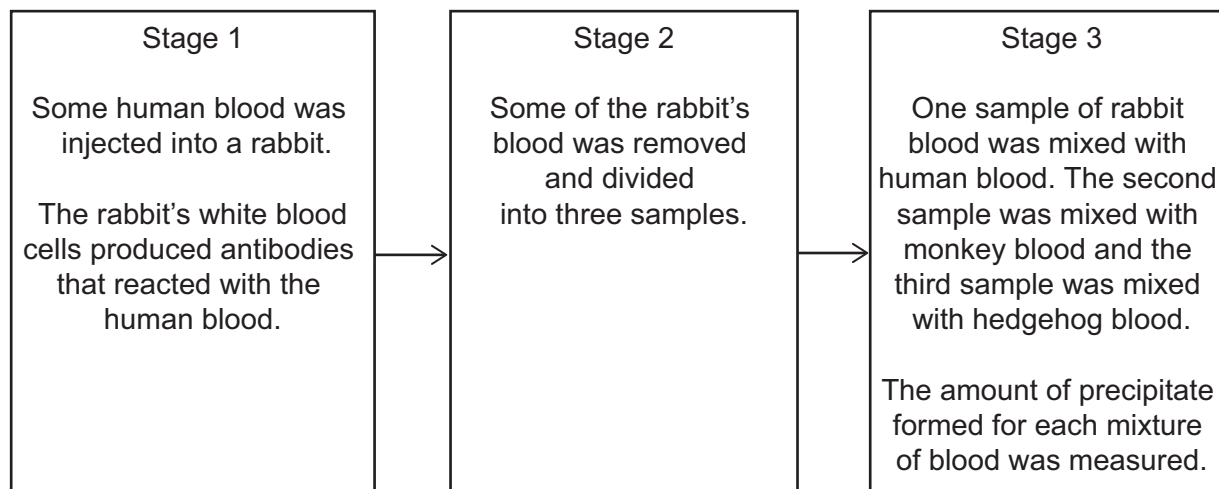

When an antigen binds to an antibody, a precipitate is formed, which is measured in stage 3.

Some of the results for stage 3 are shown in the table.

P and Q each represent one of the non-human mammals.

<i>species of mammal</i>	<i>amount of precipitate formed / arbitrary units</i>
P	58
Q	17

Which row is correct for this investigation?

	<i>biological molecules that form antibodies in stage 1</i>	<i>the amount of precipitate formed for the sample with human blood in stage 3 / arbitrary units</i>	<i>species Q</i>
A	amino acids	greater than 58	monkey
B	amino acids	greater than 58	hedgehog
C	amino acids	less than 17	monkey
D	amino acids	less than 17	hedgehog
E	nucleotides	greater than 58	monkey
F	nucleotides	greater than 58	hedgehog
G	nucleotides	less than 17	monkey
H	nucleotides	less than 17	hedgehog

